

CRATE SIZES:

- A. 100 x 37 x 73 ~2095 lbs
- B. 100 x 53 x 73 ~2315 lbs
- C. 94 x 40 x 24 ~295 lbs

- MINIMUM HEAD ROOM FOR RAISING THE HEAT EXCHANGER SECTION IS 98'-1 1/2"

UTILITY SCHEDULE

1. WATER CONNECTION, 3/8" NPT
2. WATER DRAIN CONNECTION 1/2" NPT FRONT STANDARD, REAR AVAILABLE
3. ELECTRICAL CONNECTION
4. DAMPER CONNECTION, AUTOMATIC OVERPRESSURE DAMPER, ø6.3"
5. 12" DIA. HOOD CONNECTION
6. SUPPLY AIR, EVACUATION STEAM 4"x1-1/2"
7. 10" DIA. FLUE GAS CONNECTION
8. GAS CONNECTION 3/4" NPT

CONSTRUCTION:

- STAINLESS STEEL INTERIOR AND EXTERIOR
- ROCK WOOL MINERAL INSULATION THROUGHOUT

PLUMBING:

- 1/2" DRAIN CONNECTION
- 3/8" WATER LINE @ 50-80 PSI WATER PRESSURE
- WATER PRESSURE REGULATOR AND WATER FILTER RECOMMENDED, BUT NOT SUPPLIED

FUEL SPECIFICATIONS:

TYPE: NATURAL GAS, (PROPANE OPTIONAL)
 POWER INPUT: 340,000 BTUH - NATURAL GAS, PROPANE
 SUPPLY PRESSURE: 5.5-14.0" WC NATURAL GAS, PROPANE
 - REFER TO THE BURNER MANUAL FOR PROPER MAINTENANCE, ADJUSTMENTS AND OPERATING INSTRUCTIONS.

ELECTRICAL SPECIFICATIONS:

- 2 CONNECTIONS REQUIRED: 208-240 V / 3 PH / 60 HZ / 15 A BRANCH CIRCUIT 120 V / 1 PH / 60 HZ / 15 A BRANCH CIRCUIT
- OPTIONAL: AVAILABLE AT EXTRA COST: 440-480 V / 3 PH / 60 HZ / 15 A BRANCH CIRCUIT

VENTING SPECIFICATIONS:

- GREASE HOOD EXHAUST VENT TO LOCAL CODE (1200 CFM MIN.)
- CHECK OVERFIRE DRAFT AND ADJUST TO NEGATIVE: -.04 to -.20 INCHES W.C. USING FIRE CHAMBER SIGHT GLASS PORT DURING BURNER OPERATION

NOTES:

1. INSTALLATION MUST COMPLY WITH ALL NATIONAL, STATE AND LOCAL CODES IN EFFECT AT THE TIME OF INSTALLATION.
2. THE OVEN SHOULD BE INSTALLED ON A NON-COMBUSTIBLE FLOOR WITH AN INCLINATION NOT TO EXCEED 1/16" PER FOOT.
3. INSTALLATIONS AND START-UP MUST BE PERFORMED BY A QUALIFIED TECHNICIAN.
4. IMPROPER INSTALLATION, ADJUSTMENT, ALTERATION, SERVICE OR MAINTENANCE CAN CAUSE PROPERTY DAMAGE, INJURY OR DEATH. READ THE INSTALLATION, OPERATING AND MAINTENANCE INSTRUCTIONS THOROUGHLY BEFORE INSTALLING OR SERVICING THIS EQUIPMENT.
5. *ALL EXHAUST DUCTING TO BE DONE BY OTHERS, (CONNECTIONS FROM AND TO DAMPERS, HOOD, STACKS, FANS AND CAPS ETC TO BE SUPPLIED AND INSTALLED BY OTHERS.)
6. FREE DOOR OPENING, 42.12" x 75.08"
7. WEIGHT, APPROX. 1700K ± NET. (-4300LBS)

*-POWERED CANOPY EXHAUST 1200 CFM

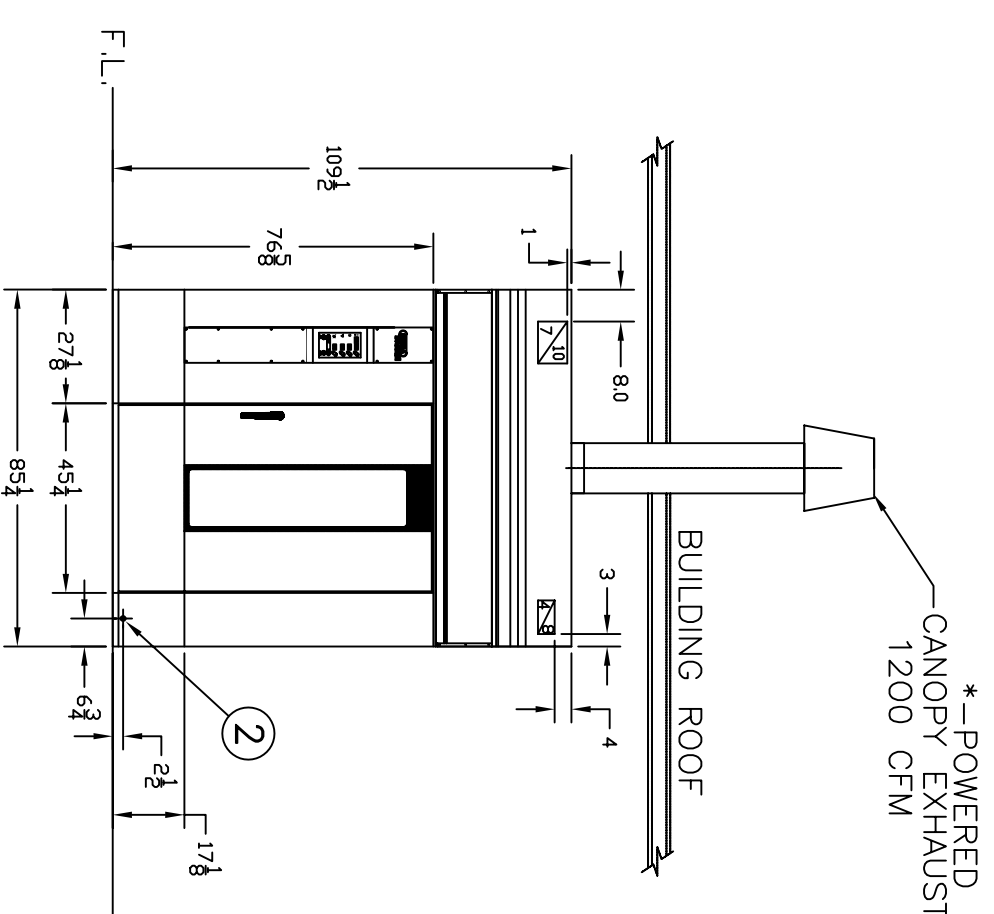

*-POWERED CANOPY EXHAUST 1200 CFM

GREASE CANOPY AS PER MANUFACTURE DRAWING NO. 99-V42-304-SPGC

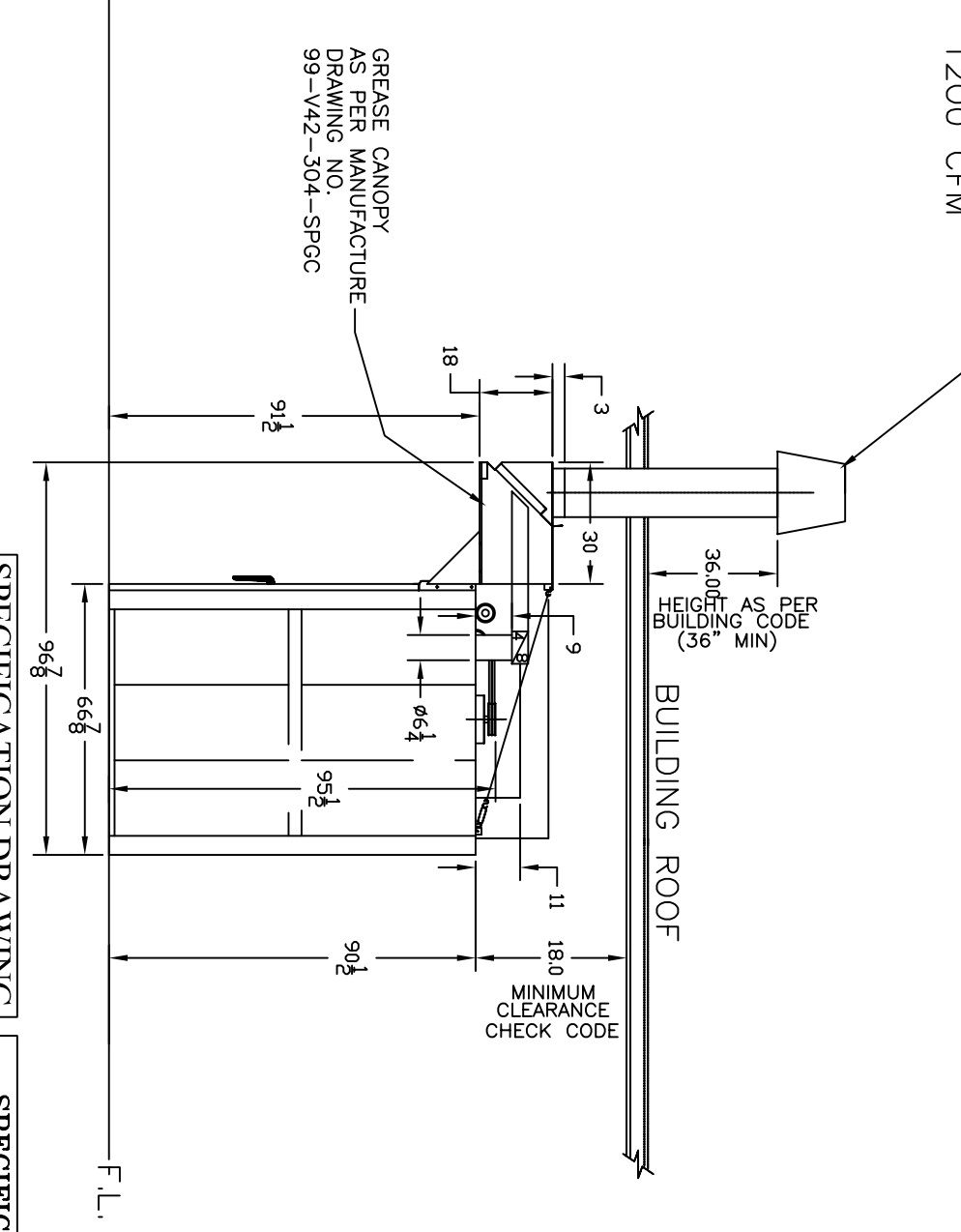

SPECIFICATION DRAWING
 SUBJECT TO CHANGE
 WITHOUT NOTICE

SPECIFICATION DRAWING
 FOR CONSTRUCTION
 DIMENSIONS ARE APPROXIMATE

BY	DATE	SCALE	SIZE
DAC	5/06/02	1/2" = 1'	D
REVISION NUMBER	DWG NO		
11/03	SPECV42LEP-SPGC		

9990 GANTTRY ROAD, PHILADELPHIA, PA 19115, USA, phone (215) 673-3620 fax (215) 673-3644

THIS PRINT IS PROPERTY OF THE GEMINI BAKERY EQUIPMENT CO. SUBJECT TO RETURN OR EXCHANGE, AND IS LOANED WITH NO RIGHTS OF INDEMNITY, IN ANY WAY DETERMINED, TO THE INTERESTS OF THE GEMINI BAKERY EQUIPMENT CO.

SINGLE POINT GREASE CANOPY
 V42 GAS FIRED E-PANEL RACK OVEN